

# ICC-ES Evaluation Report

## ESR-3179

Reissued October 2018

Revised November 2019

This report is subject to renewal October 2020.

[www.icc-es.org](http://www.icc-es.org) | (800) 423-6587 | (562) 699-0543

A Subsidiary of the International Code Council®

**DIVISION: 06 00 00—WOOD, PLASTICS AND COMPOSITES**  
**Section: 06 05 23—Wood, Plastic, and Composite Fastenings**

### REPORT HOLDER:

**SCHRAUBENWERK GAISBACH GmbH (SWG)**

### EVALUATION SUBJECT:

**SWG ASSY 3.0 WOOD SCREWS**

## 1.0 EVALUATION SCOPE

### Compliance with the following codes:

- 2015, 2012, 2009 and 2006 *International Building Code*® (IBC)
- 2015, 2012, 2009 and 2006 *International Residential Code*® (IRC)

### Property evaluated:

Structural

## 2.0 USES

SWG Assy 3.0 screws are alternate dowel-type threaded fasteners used in engineered wood-to-wood connections. The fasteners may be used under the IRC when an engineered design is submitted in accordance with IRC Section R301.1.3.

## 3.0 DESCRIPTION

### 3.1 General:

SWG Assy 3.0 screws have a gimlet point, and one of four head styles: hex (designated “Kombi”), washer (designated “SK”), flat head washer (FWH or SK II) or countersunk with milling pockets (designated ECO). The heads have a recess for use with an AW drive, which is a proprietary driving bit available from the report holder. The screws are available with nominal diameters of 1/4, 5/16, 3/8 and 1/2 inch (6, 8, 10 and 12 mm). The screws are partially threaded, and are available in varying lengths as shown in Table 1. Select screw lengths [(typically greater than 6 inches) (152 mm)] have a shank cutter design between the threads. The specified diameters and other dimensions are provided in Table 1 for each screw. The screws are available in boxes of loose fasteners.

### 3.2 Materials:

**3.2.1 SWG Assy 3.0 Screws:** All four types of SWG Assy 3.0 screws are manufactured from carbon steel. The

Kombi, SK and ECO types of Assy 3.0 screws are also manufactured from stainless steel.

**3.2.1.1 Carbon Steel Screws:** The screws are manufactured from carbon steel wire complying with the manufacturer’s specifications. After the heads are formed and the threads are rolled, the screws are hardened, in accordance with the manufacturer’s specifications. The hardened screws are then galvanized with a minimum zinc coating thickness of 0.0002 inch (5 µm) and coated with a lubricant. See Figures 1 through 4 for depictions of the screws.

**3.2.1.2 Stainless Steel Screws:** The screws are manufactured from Grade A2 stainless steel wire complying with EN 10088-3 and EN 10263-5. In general, they have tighter thread pitch than carbon steel Assy 3.0 screws of the same nominal diameter. See Figures 5 through 7 for depictions of the screws.

**3.2.2 Wood Members:** Wood members may be sawn lumber or parallel strand lumber (PSL) which is a type of structural composite lumber (SCL). Sawn lumber side and main members must have a moisture content less than or equal to 19 percent at the time of screw installation and while in service. For PSL, the moisture content at the time of installation and in service must be in accordance with the applicable ICC-ES evaluation report on the PSL. Sawn lumber must have an assigned specific gravity, as specified in Table 12.3.3A of the 2015 ANSI/AWC *National Design Specification for Wood Construction*® (NDS-15) (Table 11.3.3A of NDS-12 for the 2012 IBC, Table 11.3.2A of NDS-05 for the 2009 and 2006 IBC) within the ranges given in the tables in this report. PSL must have a minimum equivalent specific gravity, given in the applicable ICC-ES evaluation report, of 0.50. The thickness of the wood main member,  $t_m$ , must be equal to or greater than the screw length less the thickness of the side member,  $t_s$ . The minimum thickness of both main and side members must also be as follows: 15/16 inch (24 mm) for 1/4-inch-diameter (6 mm) screws; 13/16 inches (30 mm) for 5/16-inch-diameter (8 mm) screws; 19/16 inches (40 mm) for 3/8-inch-diameter (10 mm) screws; and 33/16 inches (80 mm) for 1/2-inch-diameter (12 mm) screws.

## 4.0 DESIGN AND INSTALLATION

### 4.1 Design:

**4.1.1 Governing Design Values:** The allowable lateral load for a single-screw connection is the lesser of: (a) the reference lateral design value described in Section 4.1.2, adjusted by all applicable adjustment factors, and (b) the allowable screw shear strength given in Table 1. The

allowable load for a single-screw connection in which the screw is subject to tension is the least of: (a) the reference withdrawal design value described in Section 4.1.3, adjusted by all applicable adjustment factors; (b) the reference head pull-through design value described in Section 4.1.3, adjusted by all applicable adjustment factors; and (c) the allowable screw tension strength given in Table 1.

**4.1.2 Reference Lateral Design Values (Z):** Reference lateral design values (Z) for single shear, wood-to-wood connections with the SWG Assy 3.0 carbon steel and stainless steel screws loaded parallel or perpendicular to grain may be determined in accordance with Section 12.3.1 of NDS-15 (Section 11.3.1 of NDS-12 for the 2012 IBC and NDS-05 for the 2009 and 2006 IBC) using the following parameters and limitations:

1. The applicable specified bending yield strength from Table 1 must be used for design.
2. The wood side member thickness must be a minimum of 1<sup>3</sup>/<sub>4</sub> inches (45 mm).
3. The minimum fastener penetration into the main member, excluding tip length, must be 6D.
4. For sawn lumber, the specific gravity used for design purposes must be the assigned specific gravity per Table 12.3.3.A of NDS-15 (Table 11.3.3A of NDS-12 for the 2012 IBC, Table 11.3.2A of NDS-05 for the 2009 and 2006 IBC).
5. For PSL, the specific gravity used for design purposes must be the equivalent specific gravity for the PSL given in the applicable ICC-ES evaluation report.

Reference lateral design values (Z) for select wood-to-wood connection configurations are given in Table 2.

**4.1.3 Reference Withdrawal Design Values (W) and Head Pull-through (P) Design Values:** Reference withdrawal design values (W) for SWG Assy 3.0 screws are given in Table 3. Reference head pull-through design values (P) are given in Table 4.

**4.1.4 Adjustments to Reference Design Values:** Reference design values must be adjusted in accordance with the requirements in Section 11.3 of NDS-15 (Section 10.3 of NDS-12 for the 2012 IBC and NDS-05 for the 2009 and 2006 IBC) for dowel-type fasteners. Use is limited to dry in-service conditions, such that the wet service factor,  $C_M$ , is 1.0 in accordance with the NDS. The reference design values must also be adjusted in accordance with the requirements in Section 12.5 of NDS-15 (Section 11.5 of NDS-12 for the 2012 IBC and NDS-05 for the 2009 and 2006 IBC).

**4.1.5 Connections with Multiple Screws:** Connections containing multiple SWG Assy 3.0 screws must be designed in accordance with Sections 11.2.2 and 12.6 of NDS-15 (Sections 10.2.2 and 11.6 of NDS-12 for the 2012 IBC and NDS-05 for the 2009 and 2006 IBC).

**4.1.6 Combined Loading:** Where SWG Assy 3.0 screws are subjected to combined lateral and withdrawal loads, connections must be designed in accordance with Section 12.4.1 of NDS-15 (Section 11.4.1 of NDS-12 for the 2012 IBC and NDS-05 for the 2009 and 2006 IBC).

**4.1.7 Capacity Requirements for Wood Members:** When designing a connection, the structural members must be checked for load-carrying capacity in accordance with Section 11.1.2 of NDS-15 (Section 10.1.2 of NDS-12 for the 2012 IBC and NDS-05 for the 2009 and 2006 IBC), and local stresses within the connection must be checked against Appendix E of the NDS to ensure the capacity of the connection and fastener group.

## 4.2 Installation:

**4.2.1 General:** SWG Assy 3.0 screws must be installed in accordance with the manufacturer's published installation instructions and this report. Screws must be installed such that their main axis is oriented perpendicular to the wood grain of side and main members. An appropriate screw length must be used, such that the screw will penetrate a minimum of 6 diameters into the main member for lateral connections; a minimum of 8 diameters into the main member for tension connections with carbon steel screws; and a minimum of 6 diameters into the main member for tension connections with stainless steel screws. The side member must be in direct contact with the main member, such that no gap exists between the wood members.

Screws must be installed using the manufacturer-recommended drive bit, with a rotary drill, or a percussion drill set to rotary only mode. Upon installation, the flat surface of the countersunk heads and the flat washer heads must be flush with the surface of the side member. The screws must not be overdriven.

**4.2.2 End Distance, Edge Distance and Spacing:** Minimum end distances, edge distances and spacing of the screws must be sufficient to prevent splitting of the wood, or as required by Table 5, whichever is greater. When the screws are used in PSL, the minimum fastener end and edge distances and spacing must be in accordance with Table 5 or in accordance with the ICC-ES evaluation report on the PSL, whichever is more restrictive.

**4.2.3 Pilot Holes:** Typical installation of SWG Assy 3.0 screws does not require predrilling of the wood members; however predrilling of holes to reduce splitting is recommended by the manufacturer for the following conditions:

1. For species which are prone to splitting, including various species of spruce and fir, including Douglas fir.
2. For lumber with thickness  $\leq 1\frac{1}{2}$  inches (35 mm).
3. For laterally loaded screws installed in lumber with a thickness  $\leq 7D$  ( $\leq 14D$  for various species of spruce and fir, including Douglas fir).
4. For axially loaded screws installed in lumber with a thickness  $\leq 10D$  and/or a width of less than  $8D$  or 60 mm ( $2\frac{3}{8}$  inches), whichever is greater.

For recommended sizes of predrilled holes, see Table 6.

## 5.0 CONDITIONS OF USE

The SWG Assy 3.0 screws described in this report comply with, or are suitable alternatives to what is specified in, those codes listed in Section 1.0 of this report, subject to the following conditions:

- 5.1** The screws must be installed in accordance with the manufacturer's published installation instructions and this report. In case of a conflict between this report and the manufacturer's installation instructions, this report governs.
- 5.2** Calculations and details demonstrating compliance with this report must be submitted to the code official. The calculations and details must be prepared by a registered design professional where required by the statutes of the jurisdiction in which the project is to be constructed.
- 5.3** SWG Assy 3.0 screws must be installed and used in dry in-service conditions where the moisture content of the wood members does not exceed 19 percent.

- 5.4 Use of the screws in contact with preservative-treated or fire-retardant-treated wood is outside the scope of this report.
- 5.5 Assy 3.0 screws are manufactured under a quality control program with inspections by ICC-ES.

## 6.0 EVIDENCE SUBMITTED

Data in accordance with the ICC-ES Acceptance Criteria for Alternate Dowel-type Threaded Fasteners (AC233), dated April 2015 (editorially revised August 2015).

## 7.0 IDENTIFICATION

- 7.1 Individual SWG Assy 3.0 screws are identified in the field by their unique configurations. In addition, the screw heads are marked with the letters "ASSY", and may be marked with the screw length, as shown in Figures 1 through 7. Packages of screws are identified with the manufacturer's name (SWG); product name (Assy 3.0); head type and drive size; screw diameter and length (in both inches and millimeters); and the evaluation report number (ESR-3179).

- 7.2 The report holder's contact information is the following:

**SCHRAUBENWERK GAISBACH GmbH (SWG)**  
**AM BAHNHOF 50**  
**D-74638 WALDENBURG**  
**GERMANY**  
**+49 7942 1000**  
[info@swg-produktion.de](mailto:info@swg-produktion.de)  
[www.swg-produktion.de](http://www.swg-produktion.de)

**Technical Support:**  
**MYTICON TIMBER CONNECTORS INC.**  
**(866) 899-4090**  
[info@my-ti-con.com](mailto:info@my-ti-con.com)  
[www.my-ti-con.com](http://www.my-ti-con.com)

TABLE 1—FASTENER SPECIFICATIONS AND STRENGTHS – SWG ASSY 3.0 SCREWS

	NOMINAL DIAMETER (inch)	HEAD STYLE	OUTSIDE THREAD DIAMETER (inch)	ROOT DIAMETER (inch)	SMOOTH SHANK DIAMETER (inch)	THREAD PITCH (inch)	HEAD DIAMETER (inch)	DRIVE TYPE AND SIZE	OVERALL LENGTH <sup>1</sup> (inches)	THREAD LENGTH (inch)	TIP LENGTH (inch)	SPECIFIED BENDING YIELD STRENGTH <sup>2</sup> , $F_{yb}$ (psi)	ALLOWABLE FASTENER STRENGTH	
													Tension (lbf)	Shear (lbf)
CARBON STEEL	1/4	Washer (SK) See Figure 2	0.236	0.154	0.173	0.142	0.551	AW 30	2 <sup>3</sup> / <sub>4</sub>	1 <sup>5</sup> / <sub>8</sub>	0.236	169,500	1150	685
									3 <sup>1</sup> / <sub>8</sub> to 3 <sup>1</sup> / <sub>2</sub>	2				
									3 <sup>7</sup> / <sub>8</sub>	2 <sup>3</sup> / <sub>8</sub>				
		4 <sup>3</sup> / <sub>8</sub> to 1 <sup>1</sup> / <sub>4</sub>							2 <sup>3</sup> / <sub>4</sub>					
		2 <sup>3</sup> / <sub>4</sub>							1 <sup>5</sup> / <sub>8</sub>					
		3 <sup>1</sup> / <sub>8</sub> to 3 <sup>1</sup> / <sub>2</sub>							2					
	Countersunk (ECO) See Figure 3	3 <sup>7</sup> / <sub>8</sub>	2 <sup>3</sup> / <sub>8</sub>											
		4 <sup>3</sup> / <sub>8</sub> to 1 <sup>1</sup> / <sub>4</sub>	2 <sup>3</sup> / <sub>4</sub>											
		3 <sup>1</sup> / <sub>8</sub> to 3 <sup>1</sup> / <sub>2</sub>	2											
	5/16	Hex (Kombi) See Figure 1	0.315	0.209	0.228	0.220	0.467 (width between parallel edges)	AW 40 or 12 mm hex socket	3 <sup>1</sup> / <sub>8</sub> to 3 <sup>1</sup> / <sub>2</sub>	2	0.315	150,200	1950	1320
									3 <sup>7</sup> / <sub>8</sub>	2 <sup>3</sup> / <sub>8</sub>				
									4 <sup>3</sup> / <sub>8</sub> to 7 <sup>7</sup> / <sub>8</sub>	3 <sup>1</sup> / <sub>8</sub>				
									8 <sup>5</sup> / <sub>8</sub> to 3 <sup>1</sup> / <sub>2</sub>	3 <sup>7</sup> / <sub>8</sub>				
		Washer (SK) See Figure 2	0.315	0.209	0.228	0.220	0.866	AW 40	3 <sup>1</sup> / <sub>8</sub> to 3 <sup>1</sup> / <sub>2</sub>	2				
									3 <sup>7</sup> / <sub>8</sub>	2 <sup>3</sup> / <sub>8</sub>				
									4 <sup>3</sup> / <sub>8</sub> to 7 <sup>7</sup> / <sub>8</sub>	3 <sup>1</sup> / <sub>8</sub>				
		Countersunk (ECO) See Figure 3	0.315	0.209	0.228	0.220	0.581	AW 40	8 <sup>5</sup> / <sub>8</sub> to 3 <sup>1</sup> / <sub>2</sub>	3 <sup>7</sup> / <sub>8</sub>				
									3 <sup>1</sup> / <sub>8</sub> to 3 <sup>1</sup> / <sub>2</sub>	2				
									3 <sup>7</sup> / <sub>8</sub>	2 <sup>3</sup> / <sub>8</sub>				
		Flat Washer (FWH or SK II) See Figure 4	0.315	0.209	0.228	0.220	0.719	AW40	3 <sup>1</sup> / <sub>8</sub> to 3 <sup>1</sup> / <sub>2</sub>	3 <sup>1</sup> / <sub>8</sub>				
8 <sup>5</sup> / <sub>8</sub> to 3 <sup>1</sup> / <sub>2</sub>									3 <sup>7</sup> / <sub>8</sub>					
1 <sup>3</sup> / <sub>4</sub>									1 <sup>1</sup> / <sub>4</sub>					
2 to 2 <sup>3</sup> / <sub>16</sub>									1 <sup>9</sup> / <sub>16</sub>					
2 <sup>3</sup> / <sub>8</sub> to 3 <sup>1</sup> / <sub>2</sub>	2													
3 <sup>7</sup> / <sub>8</sub>	2 <sup>3</sup> / <sub>8</sub>													

TABLE 1—FASTENER SPECIFICATIONS AND STRENGTHS – SWG ASSY 3.0 SCREWS (Continued)

	NOMINAL DIAMETER (inch)	HEAD STYLE	OUTSIDE THREAD DIAMETER (inch)	ROOT DIAMETER (inch)	SMOOTH SHANK DIAMETER (inch)	THREAD PITCH (inch)	HEAD DIAMETER (inch)	DRIVE TYPE AND SIZE	OVERALL LENGTH <sup>1</sup> (inches)	THREAD LENGTH (inch)	TIP LENGTH (inch)	SPECIFIED BENDING YIELD STRENGTH <sup>2</sup> , $F_{yb}$ (psi)	ALLOWABLE FASTENER STRENGTH	
													Tension (lbf)	Shear (lbf)
CARBON STEEL	3/8	Hex (Kombi) See Figure 1	0.394	0.248	0.283	0.260	0.583 (width between parallel edges)	AW 40 or 15 mm hex socket	3 7/8	2 3/8	0.394	136,600	2780	1725
									4 3/4 to 5 1/2	3 1/8				
									6 1/4 to 11 3/4	3 7/8				
									12 5/8 to 39 3/8	4 3/4				
		Washer (SK) See Figure 2	0.394	0.248	0.283	0.260	0.984	AW 50	3 7/8	2 3/8				
									4 3/4 to 5 1/2	3 1/8				
	Countersunk (ECO) See Figure 3	0.394	0.248	0.283	0.260	0.713	AW 40	6 1/4 to 11 3/4	3 7/8					
								12 5/8 to 39 3/8	4 3/4					
	1/2	Hex (Kombi) See Figure 1	0.472	0.283	0.323	0.260	0.661 (width between parallel edges)	AW 40 or 17 mm hex socket	3 7/8	2 3/8	0.472	166,300	3070	2095
									4 3/4 to 5 1/2	3 1/8				
									6 1/4 to 7 8/8	3 7/8				
									8 5/8 to 14 1/8	4 3/4				
Washer (SK) See Figure 2		0.472	0.283	0.323	0.260	1.142	AW 50	15 to 20 1/2	5 11/16					
								3 7/8	2 3/8					
								4 3/4 to 5 1/2	3 1/8					
								6 1/4 to 7 8/8	3 7/8					
								8 5/8 to 14 1/8	4 3/4					
								15 to 20 1/2	5 11/16					

TABLE 1—FASTENER SPECIFICATIONS AND STRENGTHS – SWG ASSY 3.0 SCREWS (Continued)

	NOMINAL DIAMETER (inch)	HEAD STYLE	OUTSIDE THREAD DIAMETER (inch)	ROOT DIAMETER (inch)	SMOOTH SHANK DIAMETER (inch)	THREAD PITCH (inch)	HEAD DIAMETER (inch)	DRIVE TYPE AND SIZE	OVERALL LENGTH <sup>1</sup> (inches)	THREAD LENGTH (inches)	TIP LENGTH (inch)	SPECIFIED BENDING YIELD STRENGTH <sup>2</sup> , <i>F<sub>yb</sub></i> (psi)	ALLOWABLE FASTENER STRENGTH													
													Tension (lbf)	Shear (lbf)												
STAINLESS STEEL	1/4	Washer (SK) See Figure 6	0.236	0.154	0.173	0.102	0.551	AW 30	1 3/8 to 1 9/16	1 5/16	0.236	99,900	602	451												
									1 3/4 to 2	1 1/4																
									2 3/16 to 2 3/8	1 7/16																
									2 3/4	1 5/8																
									3 1/8 to 3 1/2	2																
									3 7/8	2 3/8																
		4 3/8 to 5 7/8	2 3/4																							
		Countersunk (ECO, and without milling pockets) See Figure 7	0.236	0.154	0.173	0.102	0.472	AW 30	1 3/8 to 1 9/16	1 5/16																
									1 3/4 to 2	1 1/4																
									2 3/16 to 2 3/8	1 7/16																
									2 3/4	1 5/8																
									3 1/8 to 3 1/2	2																
	3 7/8								2 3/8																	
	5/16	Washer (SK) See Figure 6	0.315	0.197	0.234	0.142	0.739	AW 40	2 3/8 to 3 1/2	2	0.315	99,500	1,171	917												
									3 7/8 to 4 3/8	2 3/8																
									4 3/4 to 7 7/8	3 1/8																
									8 5/8 to 15 3/4	3 7/8																
									Countersunk (ECO) See Figure 7	0.315					0.197	0.234	0.142	0.581	AW 40	2 3/8 to 3 1/2	2					
																				3 7/8 to 4 3/8	2 3/8					
		4 3/4 to 7 7/8	3 1/8																							
		8 5/8 to 15 3/4	3 7/8																							
		3/8	Hex (Kombi) See Figure 5	0.394	0.236	0.283	0.173	0.583 (width between parallel edges)												AW 40 or 15 mm hex socket	2 3/8 to 3 1/8	2	0.394	103,600	1,729	1,235
																					3 1/2 to 4 3/8	2 3/8				
									4 3/4 to 7 7/8	3 1/8																
8 5/8 to 11 3/4									3 7/8																	
12 5/8 to 15 3/4	4 3/4																									

For SI: 1 inch = 25.4 mm, 1 lbf = 4.45 N, 1 psi = 6.89 kPa

<sup>1</sup>For the Hex and Washer head styles, overall fastener length is measured from the underside of the head to bottom of tip. For the Countersunk and Flat Washer head styles, overall fastener length is measured from top of head to bottom of tip.

<sup>2</sup>Bending yield strength determined in accordance with ASTM F1575 using the root diameter.

TABLE 2—REFERENCE LATERAL DESIGN VALUES (Z)<sup>1,2,3,4,5</sup>

FASTENER DESIGNATION <sup>1</sup>	SIDE MEMBER THICKNESS (inches)	FASTENER PENETRATION INTO MAIN MEMBER (inches)	REFERENCE LATERAL DESIGN VALUE, Z (lbf) FOR SPECIFIC GRAVITIES OF												
			0.33			0.42			0.49			0.55			
			Z <sub>  </sub>	Z <sub>L/  </sub>	Z <sub>L</sub>	Z <sub>  </sub>	Z <sub>L/  </sub>	Z <sub>L</sub>	Z <sub>  </sub>	Z <sub>L/  </sub>	Z <sub>L</sub>	Z <sub>  </sub>	Z <sub>L/  </sub>	Z <sub>L</sub>	
CARBON STEEL SCREWS	1/4" x 4"	2	3/4	131	131	131	185	185	185	213	213	213	237	237	237
	1/4" x 4 3/4"	2	2 1/2	142	142	142	185	185	185	213	213	213	237	237	237
	1/4" x 5 1/2"	2 3/4	2 1/2	148	148	148	185	185	185	213	213	213	237	237	237
	1/4" x 6 1/4"	3 1/2	2 1/2	148	148	148	185	185	185	213	213	213	237	237	237
	1/4" x 7 1/8"	4	2 7/8	148	148	148	185	185	185	213	213	213	237	237	237
	1/4" x 7 7/8"	5 1/2	2 1/8	148	148	148	185	185	185	213	213	213	237	237	237
	1/4" x 8 5/8"	6	2 3/8	148	148	148	185	185	185	213	213	213	237	237	237
	1/4" x 9 1/2"	7	2 1/4	148	148	148	185	185	185	213	213	213	237	237	237
	1/4" x 11 3/4"	7 1/2	4	148	148	148	185	185	185	213	213	213	237	237	237
	1/4" x 11 3/4"	8	3 1/2	148	148	148	185	185	185	213	213	213	237	237	237
	1/4" x 11 3/4"	9	2 1/2	148	148	148	185	185	185	213	213	213	237	237	237
	5/16" x 4 3/4"	2	2 7/16	164	131	131	234	187	187	280	224	224	311	249	249
	5/16" x 5 1/2"	2 3/4	2 7/16	185	148	148	243	194	194	280	224	224	311	249	249
	5/16" x 6 1/4"	2 3/4	3 3/16	194	156	156	243	194	194	280	224	224	311	249	249
	5/16" x 7 1/8"	3 1/2	3 5/16	194	156	156	243	194	194	280	224	224	311	249	249
	5/16" x 7 7/8"	4	2 13/16	194	156	156	243	194	194	280	224	224	311	249	249
	5/16" x 8 5/8"	5 1/2	2 13/16	194	156	156	243	194	194	280	224	224	311	249	249
	5/16" x 9 1/2"	6	3 3/16	194	156	156	243	194	194	280	224	224	311	249	249
	5/16" x 10 1/4"	7	2 15/16	194	156	156	243	194	194	280	224	224	311	249	249
	5/16" x 11"	7 1/2	3 3/16	194	156	156	243	194	194	280	224	224	311	249	249
	5/16" x 12 5/8"	8	4 5/16	194	156	156	243	194	194	280	224	224	311	249	249
	5/16" x 13 3/8"	9	4 1/16	194	156	156	243	194	194	280	224	224	311	249	249
	5/16" x 14 1/8"	10	3 13/16	194	156	156	243	194	194	280	224	224	311	249	249
	5/16" x 15 3/4"	11	4 7/16	194	156	156	243	194	194	280	224	224	311	249	249
	5/16" x 16 3/8"	12	4 1/16	194	156	156	243	194	194	280	224	224	311	249	249
	5/16" x 18 7/8"	14	4 7/16	194	156	156	243	194	194	280	224	224	311	249	249
	3/8" x 5 1/2"	2	3 1/8	292	180	160	353	227	213	396	265	252	419	300	288
	3/8" x 5 1/2"	2 3/4	2 3/8	310	194	154	366	260	219	396	292	273	419	314	297
	3/8" x 6 1/4"	2 3/4	3 1/8	325	208	176	366	265	244	396	292	273	419	314	297
	3/8" x 6 1/4"	3 1/2	2 3/8	323	217	178	366	265	233	396	292	273	419	314	297
	3/8" x 7 1/8"	3 1/2	3 1/4	325	227	202	366	265	244	396	292	273	419	314	297
	3/8" x 7 1/8"	4	2 3/4	325	227	193	366	265	244	396	292	273	419	314	297
	3/8" x 7 7/8"	4	3 1/2	325	227	205	366	265	244	396	292	273	419	314	297
	3/8" x 8 5/8"	5 1/2	2 3/4	325	227	193	366	265	244	396	292	273	419	314	297
	3/8" x 9 1/2"	5 1/2	3 5/8	325	227	205	366	265	244	396	292	273	419	314	297
	3/8" x 11 3/4"	6	5 3/8	325	227	205	366	265	244	396	292	273	419	314	297
	3/8" x 11 3/4"	7	4 3/8	325	227	205	366	265	244	396	292	273	419	314	297
	3/8" x 12 5/8"	7 1/2	4 3/4	325	227	205	366	265	244	396	292	273	419	314	297
	3/8" x 13 3/8"	8	5	325	227	205	366	265	244	396	292	273	419	314	297
	3/8" x 13 3/8"	8 1/2	5 1/4	325	227	205	366	265	244	396	292	273	419	314	297
	3/8" x 14 1/8"	9	5 5/8	325	227	205	366	265	244	396	292	273	419	314	297
	3/8" x 14 1/8"	9 1/2	5 1/8	325	227	205	366	265	244	396	292	273	419	314	297
	3/8" x 15"	10	4 5/8	325	227	205	366	265	244	396	292	273	419	314	297
	3/8" x 15 3/4"	11	4 3/8	325	227	205	366	265	244	396	292	273	419	314	297
	3/8" x 16 3/8"	11 1/2	4 1/2	325	227	205	366	265	244	396	292	273	419	314	297
3/8" x 17 1/4"	12	4 7/8	325	227	205	366	265	244	396	292	273	419	314	297	
3/8" x 18 1/8"	13	4 3/4	325	227	205	366	265	244	396	292	273	419	314	297	
3/8" x 20 1/2"	14	6 1/8	325	227	205	366	265	244	396	292	273	419	314	297	
1/2" x 7 1/8"	3 1/2	3 1/8	456	278	212	526	372	301	569	412	377	602	443	412	
1/2" x 7 7/8"	3 1/2	3 7/8	467	289	236	526	374	335	569	412	379	602	443	412	
1/2" x 7 7/8"	4	3 3/8	467	307	237	526	374	337	569	412	379	602	443	412	
1/2" x 9 1/2"	5 1/2	3 1/2	467	320	265	526	374	339	569	412	379	602	443	412	
1/2" x 10 1/4"	5 1/2	4 1/4	467	320	285	526	374	339	569	412	379	602	443	412	

TABLE 2—REFERENCE LATERAL DESIGN VALUES (Z)<sup>1,2,3,4,5</sup> (Continued)

FASTENER DESIGNATION <sup>1</sup>	SIDE MEMBER THICKNESS (inches)	FASTENER PENETRATION INTO MAIN MEMBER (inches)	REFERENCE LATERAL DESIGN VALUE, Z (lbf) FOR SPECIFIC GRAVITIES OF												
			0.33			0.42			0.49			0.55			
			Z <sub>  </sub>	Z <sub>L/  </sub>	Z <sub>⊥</sub>	Z <sub>  </sub>	Z <sub>L/  </sub>	Z <sub>⊥</sub>	Z <sub>  </sub>	Z <sub>L/  </sub>	Z <sub>⊥</sub>	Z <sub>  </sub>	Z <sub>L/  </sub>	Z <sub>⊥</sub>	
CARBON STEEL SCREWS	1/2" x 11 3/4"	6	5 1/4	467	320	285	526	374	339	569	412	379	602	443	412
	1/2" x 12 5/8"	7	5 1/8	467	320	285	526	374	339	569	412	379	602	443	412
	1/2" x 12 3/8"	7 1/2	4 5/8	467	320	285	526	374	339	569	412	379	602	443	412
	1/2" x 13 3/8"	8	4 7/8	467	320	285	526	374	339	569	412	379	602	443	412
	1/2" x 13 3/8"	8 1/2	4 3/8	467	320	285	526	374	339	569	412	379	602	443	412
	1/2" x 14 1/8"	9	4 5/8	467	320	285	526	374	339	569	412	379	602	443	412
	1/2" x 14 1/8"	9 1/2	4 1/8	467	320	285	526	374	339	569	412	379	602	443	412
	1/2" x 15"	10	4 1/2	467	320	285	526	374	339	569	412	379	602	443	412
	1/2" x 15 3/4"	11	4 1/4	467	320	285	526	374	339	569	412	379	602	443	412
	1/2" x 16 3/8"	11 1/2	4 3/8	467	320	285	526	374	339	569	412	379	602	443	412
	1/2" x 17 1/4"	12	4 3/4	467	320	285	526	374	339	569	412	379	602	443	412
	1/2" x 18 1/8"	13	4 5/8	467	320	285	526	374	339	569	412	379	602	443	412
1/2" x 20 1/2"	14	6	467	320	285	526	374	339	569	412	379	602	443	412	
STAINLESS STEEL SCREWS	1/4" x 3 1/8"	1 3/4	1 1/8	83	67	67	114	91	91	131	105	105	146	117	117
	1/4" x 4"	2	1 3/4	91	73	73	114	91	91	131	105	105	146	117	117
	1/4" x 4 3/4"	2	2 1/2	91	73	73	114	91	91	131	105	105	146	117	117
	1/4" x 5 1/2"	2 3/4	2 1/2	91	73	73	114	91	91	131	105	105	146	117	117
	5/16" x 3 1/8"	1 3/4	1 1/16	107	86	86	148	118	118	184	147	147	213	170	170
	5/16" x 4"	2	1 11/16	132	106	106	166	133	133	191	153	153	213	170	170
	5/16" x 4 3/4"	2	2 7/16	133	106	106	166	133	133	191	153	153	213	170	170
	5/16" x 5 1/2"	2 3/4	2 7/16	133	106	106	166	133	133	191	153	153	213	170	170
	5/16" x 6 1/4"	2 3/4	3 3/16	133	106	106	166	133	133	191	153	153	213	170	170
	5/16" x 7 1/8"	3 1/2	3 5/16	133	106	106	166	133	133	191	153	153	213	170	170
	5/16" x 7 1/8"	4	2 13/16	133	106	106	166	133	133	191	153	153	213	170	170
	5/16" x 7 7/8"	4 3/4	2 13/16	133	106	106	166	133	133	191	153	153	213	170	170
	5/16" x 8 5/8"	5 1/2	2 13/16	133	106	106	166	133	133	191	153	153	213	170	170
	5/16" x 9 1/2"	6	3 3/16	133	106	106	166	133	133	191	153	153	213	170	170
	5/16" x 10 1/4"	7	2 15/16	133	106	106	166	133	133	191	153	153	213	170	170
	5/16" x 11"	7 1/2	3 3/16	133	106	106	166	133	133	191	153	153	213	170	170
	5/16" x 11 7/8"	7 3/4	3 13/16	133	106	106	166	133	133	191	153	153	213	170	170
	5/16" x 14 1/4"	10	3 15/16	133	106	106	166	133	133	191	153	153	213	170	170
	3/8" x 4"	1 3/4	1 7/8	141	113	113	204	164	164	242	194	194	269	215	215
	3/8" x 4 3/4"	2	2 3/8	156	124	124	210	168	168	242	194	194	269	215	215
	3/8" x 5 1/2"	2	3 1/8	156	124	124	210	168	168	242	194	194	269	215	215
	3/8" x 5 1/2"	2 3/4	2 3/8	168	135	135	210	168	168	242	194	194	269	215	215
	3/8" x 6 1/4"	2 3/4	3 1/8	168	135	135	210	168	168	242	194	194	269	215	215
	3/8" x 6 1/4"	3 1/2	2 3/8	168	135	135	210	168	168	242	194	194	269	215	215
	3/8" x 7 1/8"	3 1/2	3 1/4	168	135	135	210	168	168	242	194	194	269	215	215
	3/8" x 7 1/8"	4	2 3/4	168	135	135	210	168	168	242	194	194	269	215	215
	3/8" x 7 7/8"	4	3 1/2	168	135	135	210	168	168	242	194	194	269	215	215

For SI: 1 inch = 25.4 mm, 1 lbf = 4.45 N.

<sup>1</sup>Fastener length shown is a minimum. Tabulated values may be applied to longer fasteners, with greater penetration into the main member.

<sup>2</sup>Tabulated reference lateral design values, Z, apply to screws driven into the side grain of the main member, such that the screws are oriented perpendicular to the grain and loaded as follows:

Z<sub>||</sub> : Both side and main members loaded parallel to grain.

Z<sub>L/||</sub> : Side member loaded perpendicular to grain; main member loaded parallel to grain

Z<sub>⊥</sub> : Both side and main members loaded perpendicular to grain.

<sup>3</sup>Reference lateral design values must be multiplied by all adjustment factors applicable to wood screws, in accordance with the NDS.

<sup>4</sup>SWG Assy 3.0 screws must be installed and used in dry in-service conditions, such that the wet service factor, C<sub>M</sub>, is 1.0 in accordance with the NDS.

<sup>5</sup>The specific gravity used for design purposes must be the assigned specific gravity for sawn lumber per NDS-15 Table 12.3.3A (Table 11.3.3A of NDS-12, Table 11.3.2A of NDS-05), or the equivalent specific gravity given in the applicable ICC-ES evaluation report on the PSL product.



TABLE 3—REFERENCE WITHDRAWAL DESIGN VALUES (*W*)<sup>1,2,3,4</sup> lbf/in

NOMINAL FASTENER DIAMETER (inch)	FOR SPECIFIC GRAVITIES (SG) AND EQUIVALENT SPECIFIC GRAVITIES (ESG) OF: <sup>5</sup>				
	SG = 0.55	SG = 0.49	SG = 0.42	SG = 0.35	ESG ≥ 0.50
<b>Carbon Steel Screws</b>					
1/4	230	202	169	137	156
5/16	279	248	212	176	179
3/8	317	280	237	190	211
1/2	334	297	254	211	223
<b>Stainless Steel Screws</b>					
1/4	n/a	162	143	n/a	n/a
5/16	n/a	211	169	n/a	n/a
3/8	n/a	211	180	n/a	n/a

For SI: 1 inch = 25.4 mm, 1 lbf = 4.45 N.

<sup>1</sup>Tabulated reference withdrawal design values, *W*, apply to screws driven into the side grain of the main member, such that the screws are oriented perpendicular to the grain and loaded in direct withdrawal.

<sup>2</sup>Values must be multiplied by all adjustment factors applicable to wood screws, in accordance with the NDS.

<sup>3</sup>SWG Assy 3.0 screws must be installed and used in dry in-service conditions, such that the wet service factor, *C<sub>M</sub>*, is 1.0 in accordance with the NDS.

<sup>4</sup>Reference withdrawal design values are to be multiplied by the length of thread penetration into the main member. Main member penetration must be at least 8 times the nominal diameter. Threaded length must not include the length of the tip.

<sup>5</sup>The specific gravity used for design purposes must be the assigned specific gravity for sawn lumber per NDS-15 Table 12.3.3A (Table 11.3.3A of NDS-12, Table 11.3.2A of NDS-05), and the equivalent specific gravity (ESG) must be the equivalent specific gravity given in the applicable ICC-ES evaluation report on the PSL product.

TABLE 4—REFERENCE HEAD PULL-THROUGH DESIGN VALUES (*P*)<sup>1,2,3</sup> lbf

NOMINAL FASTENER DIAMETER (inches)	HEAD TYPE	MINIMUM SIDE MEMBER THICKNESS, <i>t<sub>s</sub></i> (inches)	FOR SPECIFIC GRAVITIES (SG) AND EQUIVALENT SPECIFIC GRAVITIES (ESG) OF: <sup>4</sup>				
			SG = 0.55	SG = 0.49	SG = 0.42	SG = 0.35	ESG ≥ 0.50
<b>Carbon Steel Screws</b>							
1/4	Washer	1 3/8	407	356	299	244	440
	Countersunk		221	194	163	133	262
5/16	Hex		275	233	188	146	326
	Washer		685	604	510	410	732
	Countersunk		318	277	232	187	327
3/8	Flat Washer		n/a	480	406	n/a	n/a
	Hex		369	327	278	225	420
	Washer		710	660	593	513	797
1/2	Countersunk		445	385	319	246	509
	Hex		390	351	3055	257	474
	Washer		834	738	627	517	939
<b>Stainless Steel Screws</b>							
1/4	Washer	1 3/8	407	356	299	244	440
	Countersunk		221	194	163	133	262
5/16	Washer		685	604	510	410	732
	Countersunk		n/a	524	445	n/a	n/a
3/8	Hex		369	327	278	225	420

For SI: 1 inch = 25.4 mm, 1 lbf = 4.45 N.

<sup>1</sup>Tabulated head pull-through design values, *P*, must be multiplied by all adjustment factors applicable to wood screw withdrawal, in accordance with the NDS.

<sup>2</sup>Design values apply to connections with minimum side member thicknesses, *t<sub>s</sub>*, as given above.

<sup>3</sup>SWG Assy 3.0 screws must be installed and used in dry in-service conditions, such that the wet service factor, *C<sub>M</sub>*, is 1.0 in accordance with the NDS.

<sup>4</sup>The specific gravity (SG) used for design purposes must be the assigned specific gravity for sawn lumber per NDS-15 Table 12.3.3A (Table 11.3.3A of NDS-12, Table 11.3.2A of NDS-05), and the equivalent specific gravity (ESG) must be the equivalent specific gravity given in the applicable ICC-ES evaluation report on PSL product.

**TABLE 5—CONNECTION GEOMETRY REQUIREMENTS FOR SAWN LUMBER AND PSL<sup>1</sup>**

CONDITION		MINIMUM DIMENSION (in terms of nominal screw diameter, D)			
		LATERALLY LOADED SCREWS		AXIALLY LOADED SCREWS	
		SG ≤ 0.42	0.42 < SG ≤ 0.55 and PSL	SG ≤ 0.42	0.42 < SG ≤ 0.55 and PSL
End distance		10D	15D (22.5D in D-Fir)	10D	15D (22.5D in D-Fir)
Edge distance	Lateral Loading parallel to grain	5D	7D	-	-
	Lateral Loading perpendicular to grain	10D	12D	-	-
	Axial Load on fastener	-	-	5D	7D
Spacing between fasteners in a row		5D	7D (10.5D in D-Fir)	5D	7D (10.5D in D-Fir)
Spacing between rows	Loading parallel or perpendicular to grain	5D	7D	-	-
	Axial Load on fastener	-	-	5D	7D

<sup>1</sup>End distances, edge distances and screw spacing must be sufficient to prevent splitting of the wood, or as required by this table or the ICC-ES evaluation report on the PSL, whichever is the more restrictive.

<sup>2</sup>D-Fir refers to species group Douglas fir- Larch.

**TABLE 6—RECOMMENDED DIAMETER OF PREDRILLED HOLES<sup>1</sup> inches**

NOMINAL FASTENER DIAMETER (mm) [inches]	APPLICABLE LOAD CONDITION AND SPECIFIC GRAVITY		
	Screws Subject to Lateral Load		Screws Loaded Axially
	SG ≤ 0.5	SG > 0.5 and PSL	0.35 ≤ SG ≤ 0.55 and PSL
1/4	5/32	5/32	5/32
5/16	13/64	7/32	13/64
3/8	15/64	1/4	15/64
1/2	17/64	5/16	17/64

For SI: 1 inch = 25.4 mm.

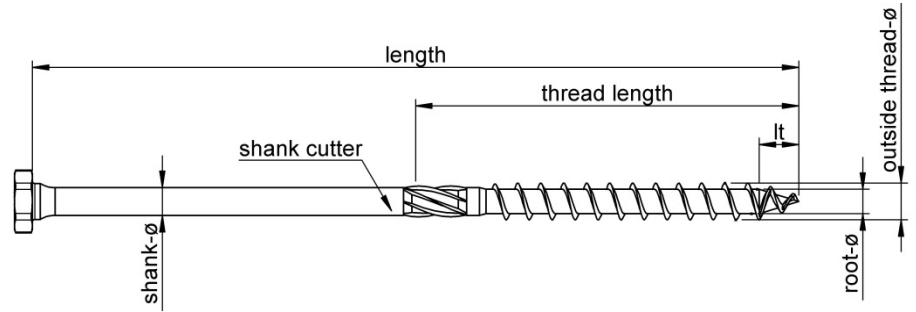
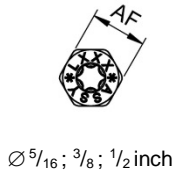

FIGURE 1—ASSY 3.0 CARBON STEEL SCREW WITH HEX HEAD (KOMBI)



$\text{Ø } 1/4 \text{ inch}$



$\text{Ø } 5/16; 3/8; 1/2 \text{ inch}$

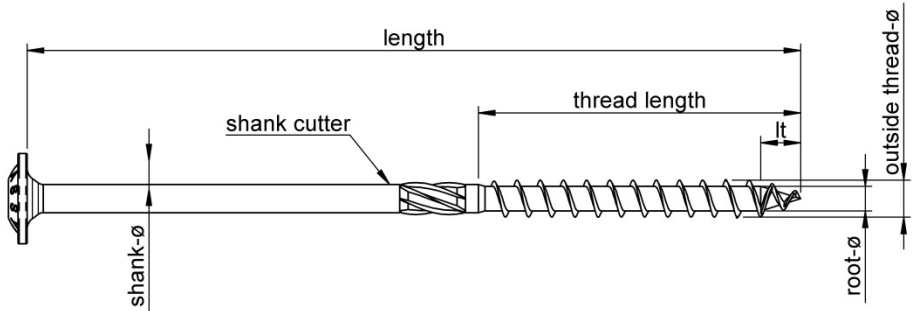

FIGURE 2—ASSY 3.0 CARBON STEEL SCREW WITH WASHER HEAD (SK)



$\text{Ø } 1/4 \text{ inch}$



$\text{Ø } 5/16; 3/8 \text{ inch}$

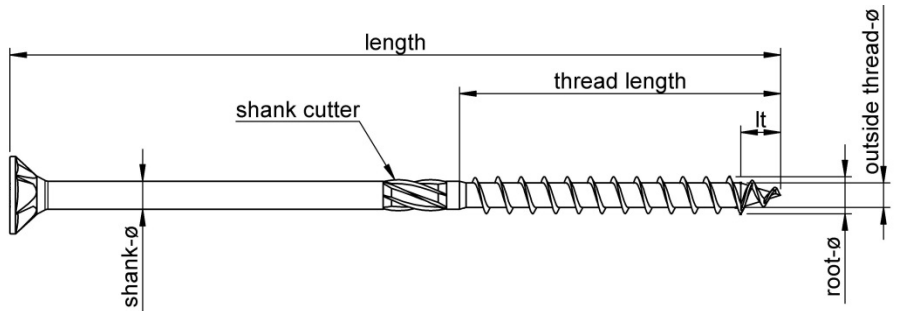
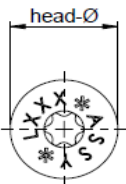

FIGURE 3—ASSY 3.0 CARBON STEEL SCREW WITH COUNTERSUNK HEAD WITH MILLING POCKETS (ECO)



$\text{Ø } 5/16 \text{ inch}$

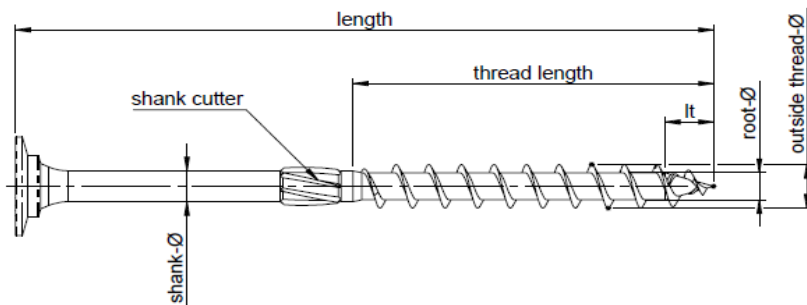

FIGURE 4—ASSY 3.0 CARBON STEEL SCREW WITH FLAT WASHER HEAD (FWH OR SK II)

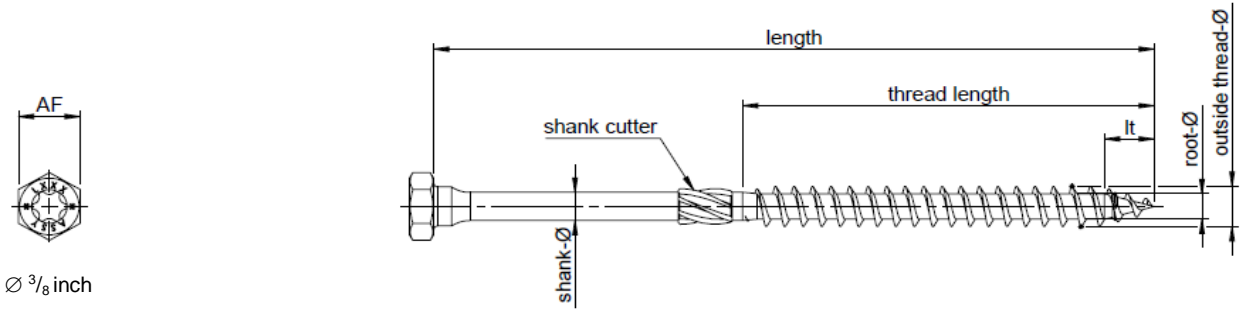

FIGURE 5—ASSY 3.0 STAINLESS STEEL SCREW WITH HEX HEAD (KOMBI)

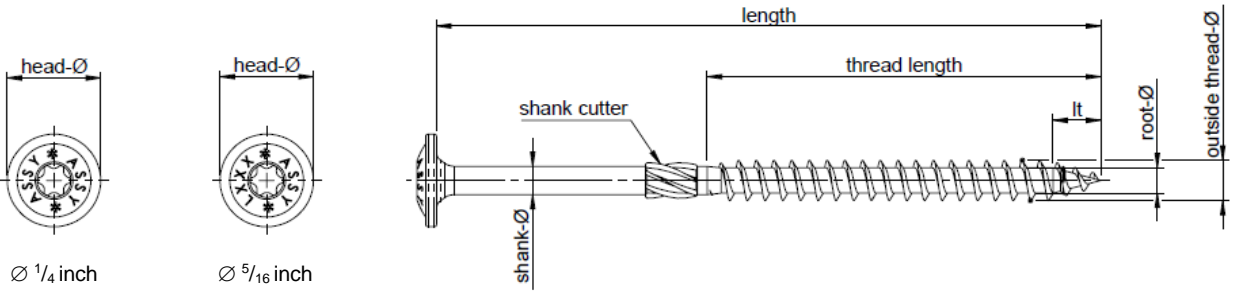

FIGURE 6—ASSY 3.0 STAINLESS STEEL SCREW WITH WASHER HEAD (SK)

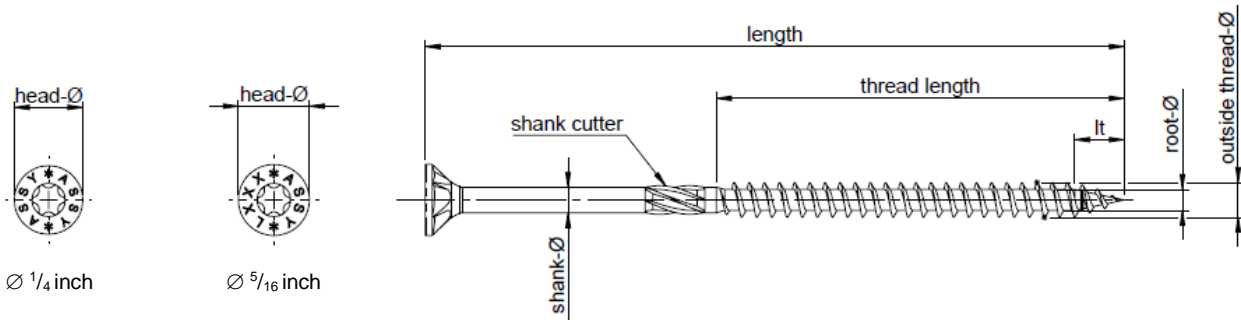

FIGURE 7—ASSY 3.0 STAINLESS STEEL SCREW WITH COUNTERSUNK HEAD WITH MILLING POCKETS (ECO)  
 Note: Assy 3.0 screw with countersunk head without milling pockets is similar.